

Van Cleef & Arpels

手動上鏈按需報時逆跳機芯

1. 閱讀時間

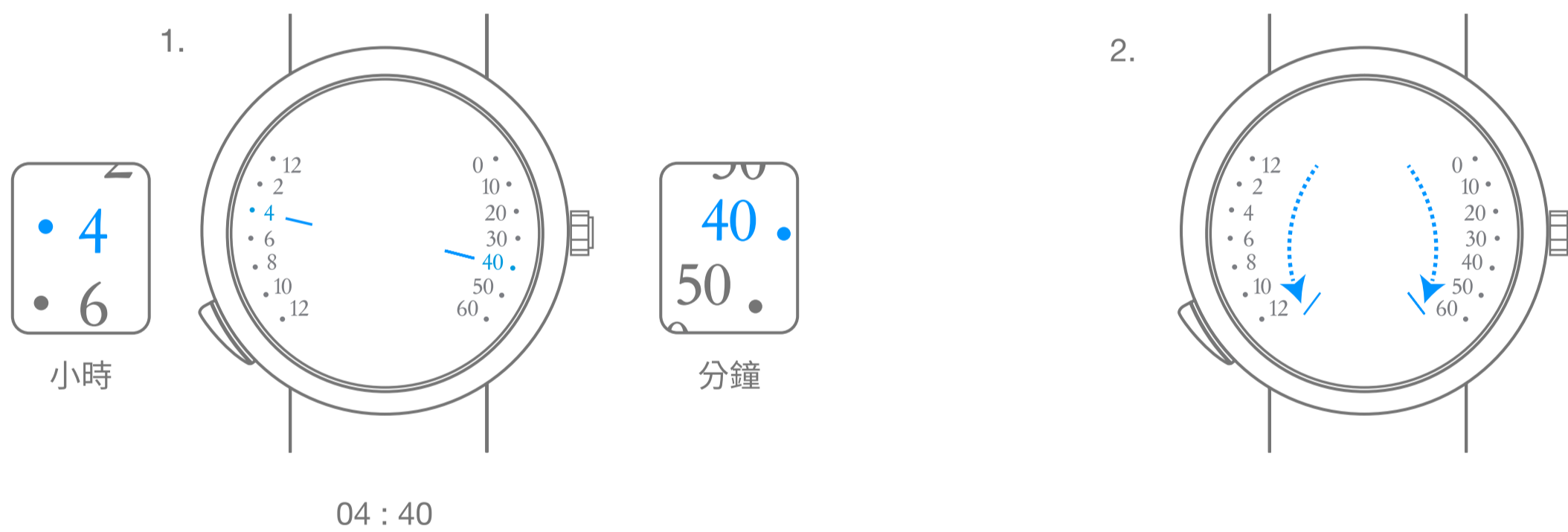
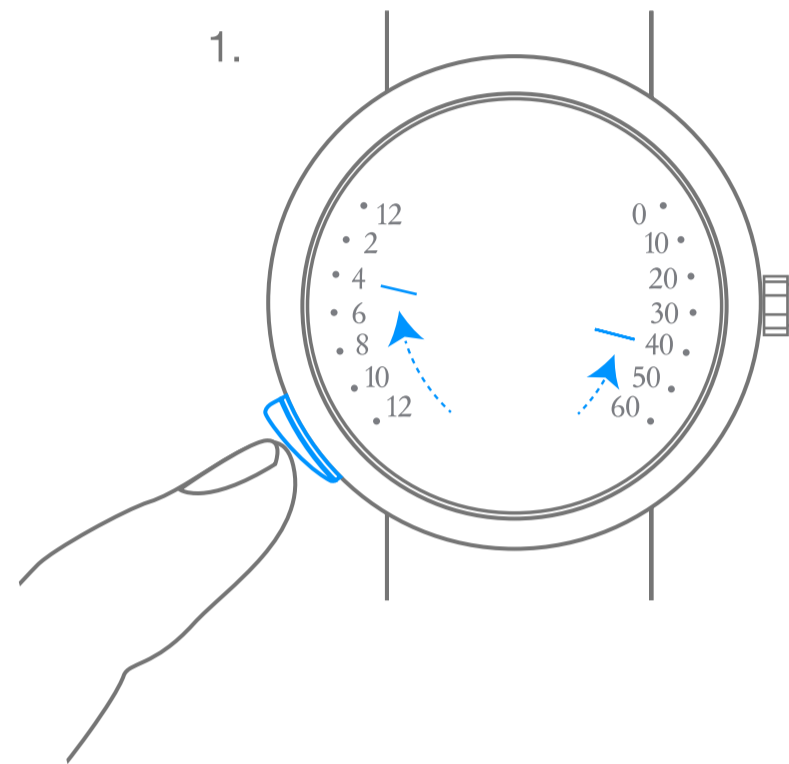

2. 腕錶上鏈

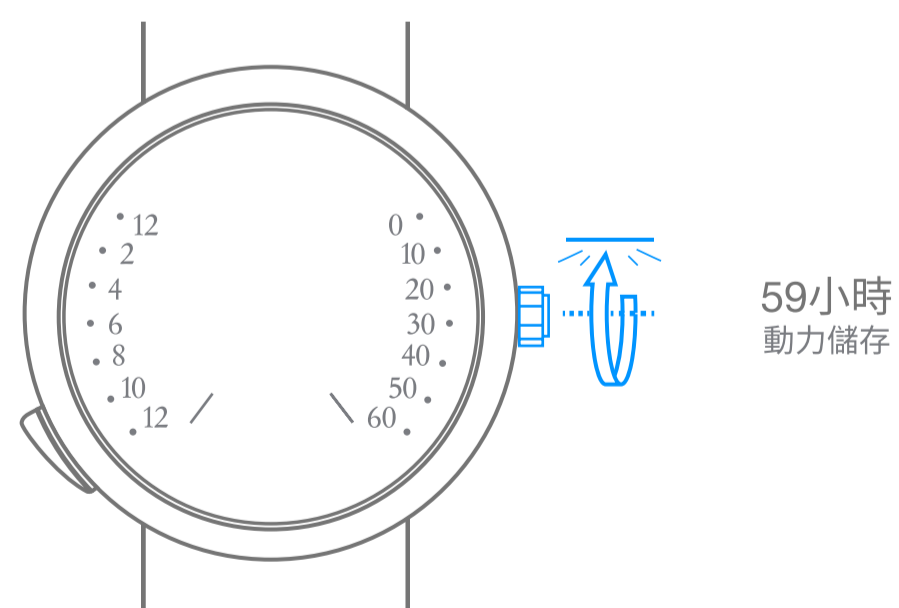

Van Cleef & Arpels

手動上鏈按需報時逆跳機芯

3. 設置時間

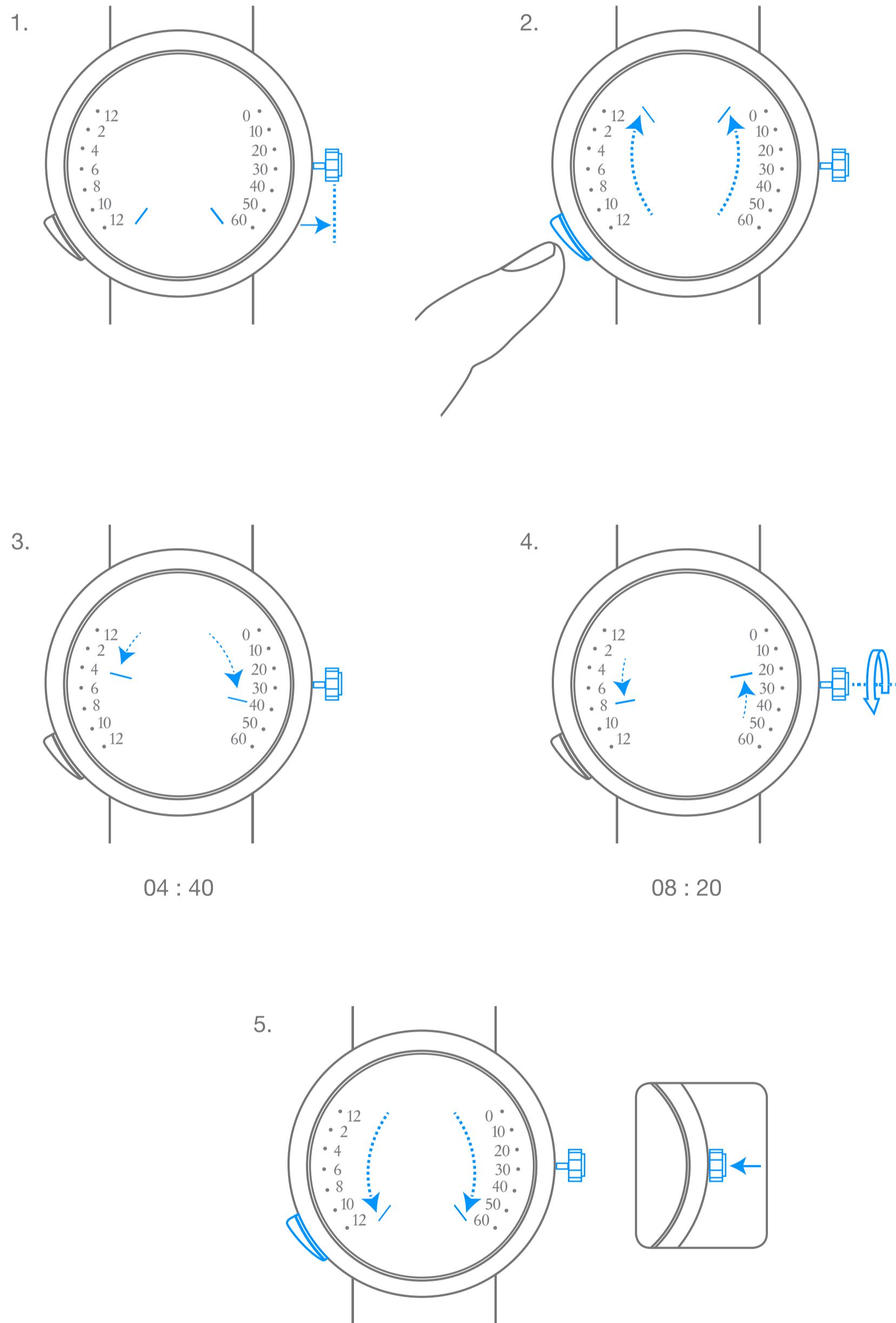

Van Cleef & Arpels

圖形符號

00小時
動力儲存

腕錶的動力儲存



請注意，在上鏈和設置時間之間需等待30秒

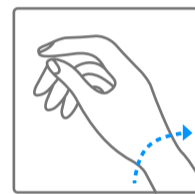

利用手腕的運動來自動上鏈



順時針旋轉

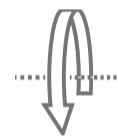

逆時針旋轉

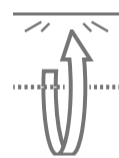

順時針旋轉，
直到出現阻力

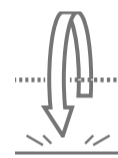

逆時針旋轉，
直到出現阻力



本地時間

本地時間



第二時區

選定國家的時間



高音鳴響



低音鳴響