

Van Cleef & Arpels

매뉴얼 와인딩 콰티엠 드 세종 무브먼트

1. 시간 확인하기

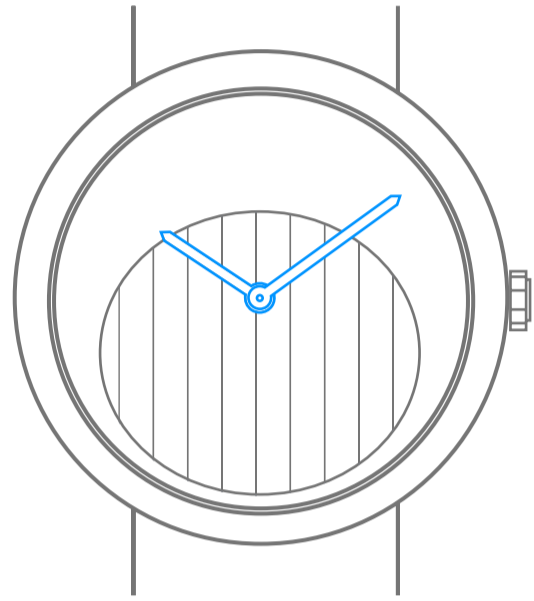

10 : 10

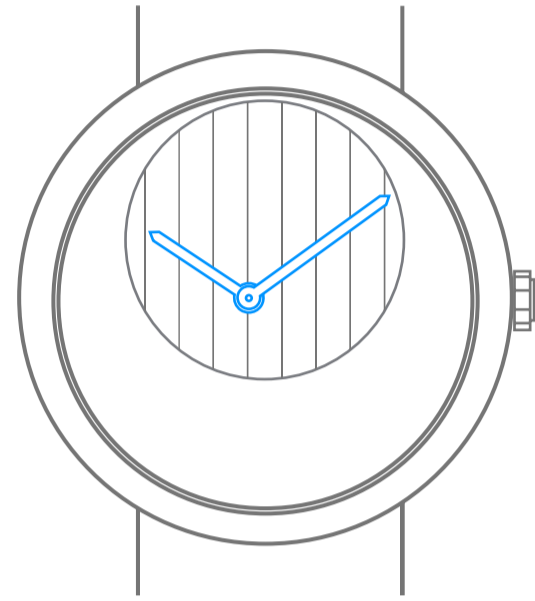

10 : 10

2. 시계 와인딩

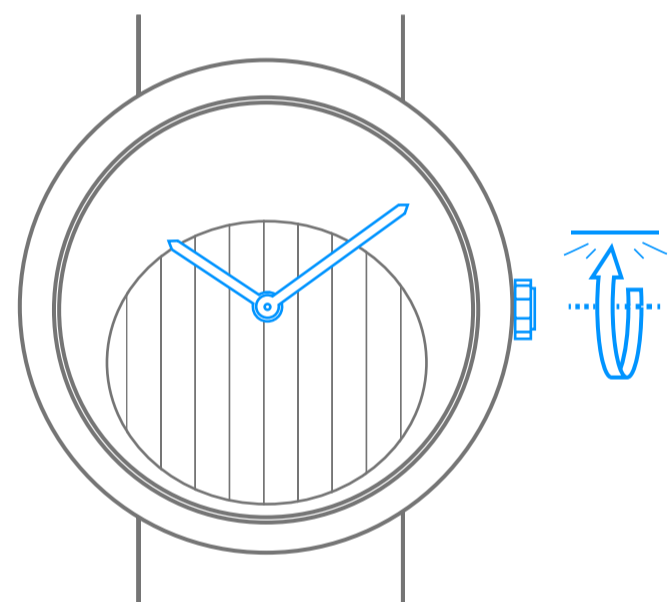

30시간
오토노미

미드나잇 인 파리

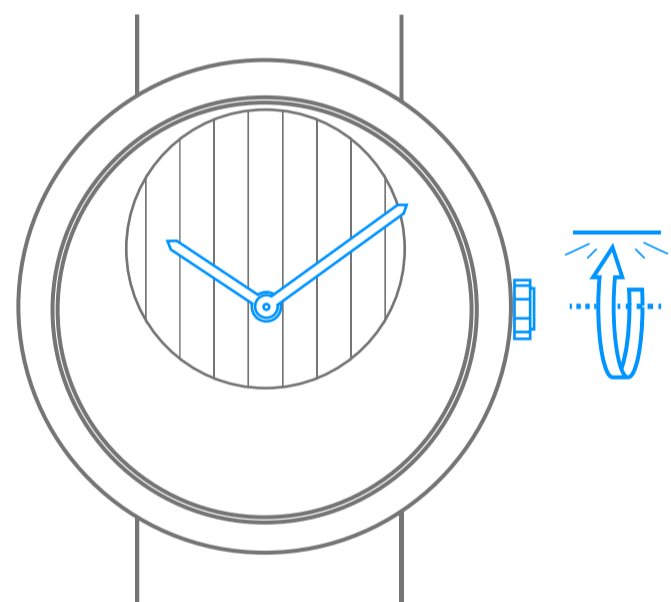

40시간
오토노미

레이디 아펠 워 필랑테

3. 시간 설정하기

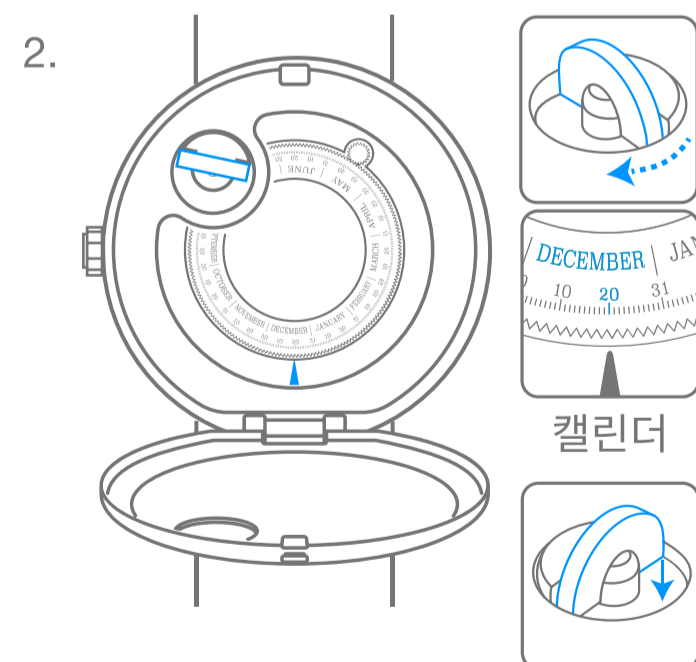
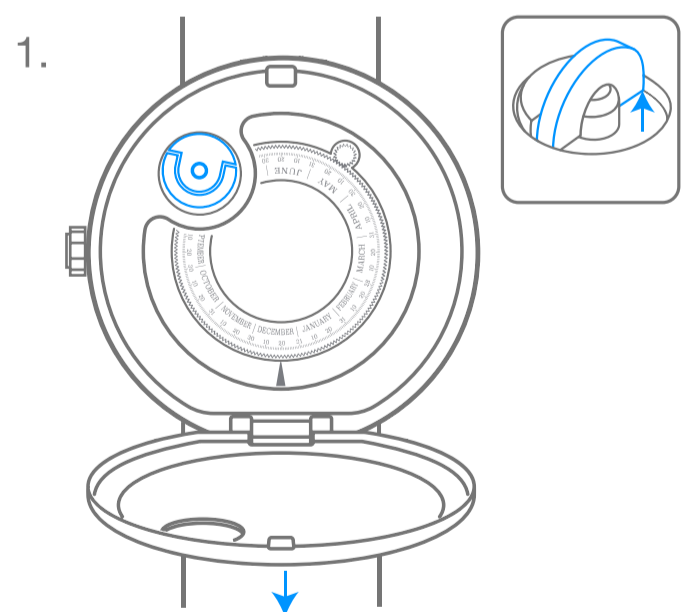

캘린더

Van Cleef & Arpels

매뉴얼 와인딩 콰티엠 드 세종 무브먼트

4. 레이디 아펠 워 필랑테 날짜 설정하기

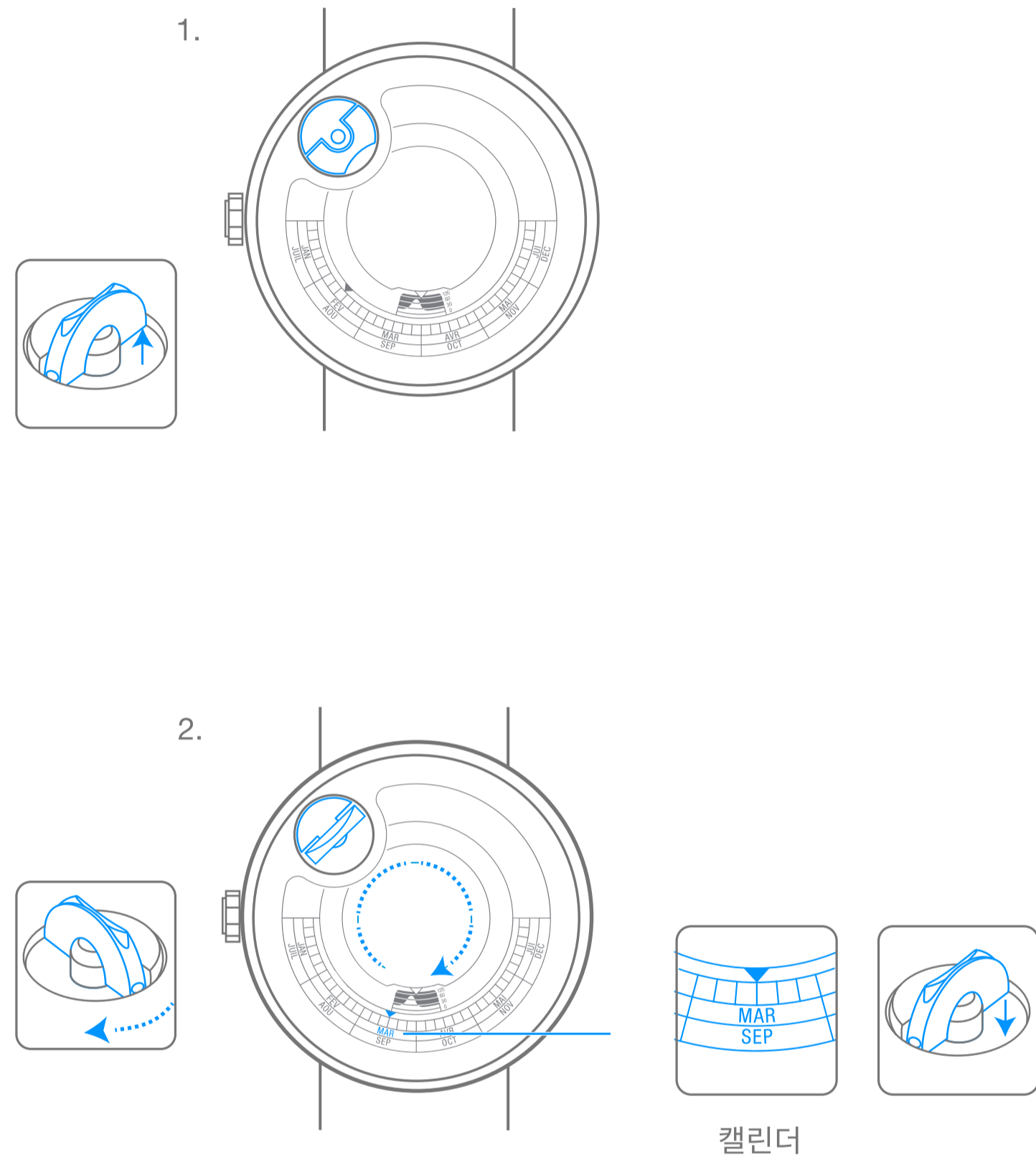

5. 시간 설정하기

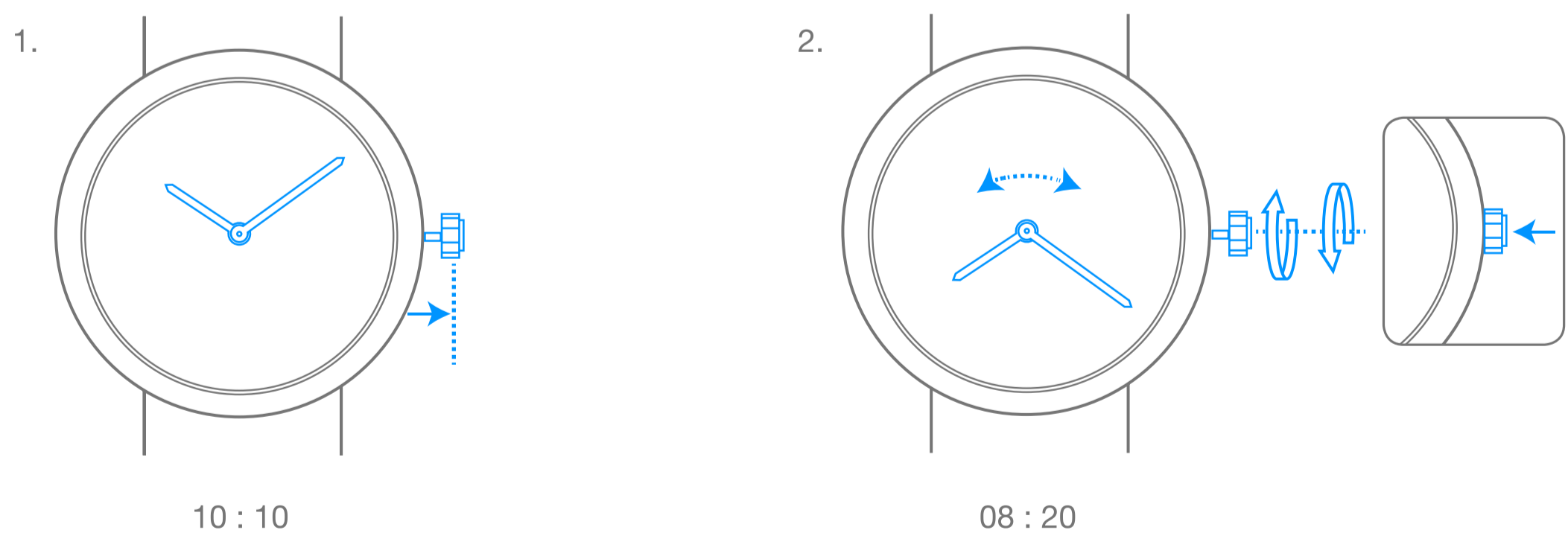

Van Cleef & Arpels

픽토그램

00시간
오토노미

파워 리저브



중요: 와인딩이 끝나면 30초 동안 기다린 후 시간을 설정하십시오

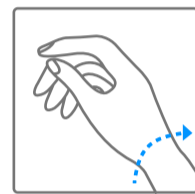

손목의 움직임으로 와인딩되는 셀프 와인딩 무브먼트



시계 방향 회전



시계 반대 방향 회전

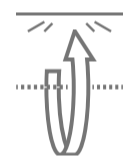

저항이 느껴질 때까지
시계 방향으로 회전

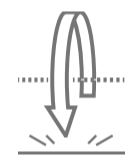

저항이 느껴질 때까지
시계 반대 방향으로 회전



현지시간

현지시간



세인트 타임존

선택한 국가의 시간



고음



저음